

'Random' Flasher for 8 LEDs Project

This project flashes eight LEDs in an apparently random manner. It uses a 4060 combined counter and display driver IC which is designed for driving 7-segment LED displays. The sequence is not really random because seven of the LEDs would normally be the display segments, the eighth LED is driven by an output that is normally used for driving further counters. The table below shows the sequence for the LEDs. You can use less than eight LEDs if you wish and the table may help you decide which ones to use for your purpose. Resistors are not required for the LEDs because the 4026 IC limits the current to about 5mA for each one.

Parts Required

- resistors: 10k, 47k
- capacitor: 1µF 16V radial
- LEDs ×8 (any colour)
- battery snap for 9V PP3
- 555 timer IC
- 4026 counter and display driver IC
- DIL sockets for ICs: 8-pin, 16-pin
- stripboard: 16 rows × 14 holes

LED sequence

Outputs from the 4026 counter and display driver IC								
Count	a	b	c	d	e	f	g	h
0	•	•	•	•	•	•		•
1		•	•					•
2	•	•						•
3	•	•	•	•				•
4		•	•			•	•	•
5	•		•	•		•	•	
6	•		•	•	•	•	•	
7	•	•	•					
8	•	•	•	•	•	•	•	
9	•	•	•	•	•	•	•	

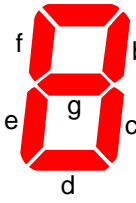

7-segment display

• = segment on. h is used to drive other counters.

Stripboard Layout

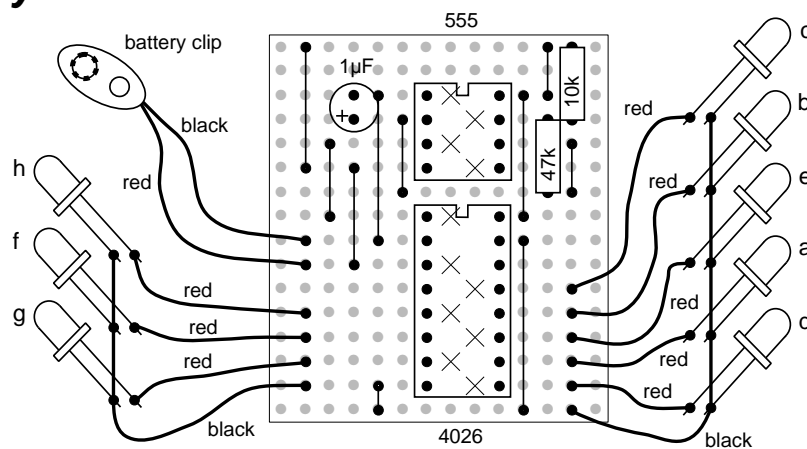

11 tracks to cut under the chip holders, shown ×
 Note: do NOT cut between pins 2 and 15 of 4026.

Circuit diagram

